

HEAVY DUTY 3 POINT RIPPER

PARTS BOOK

MODELS: H53630, H73620, H73622, H73624 & H73630



www.porterswelding.com

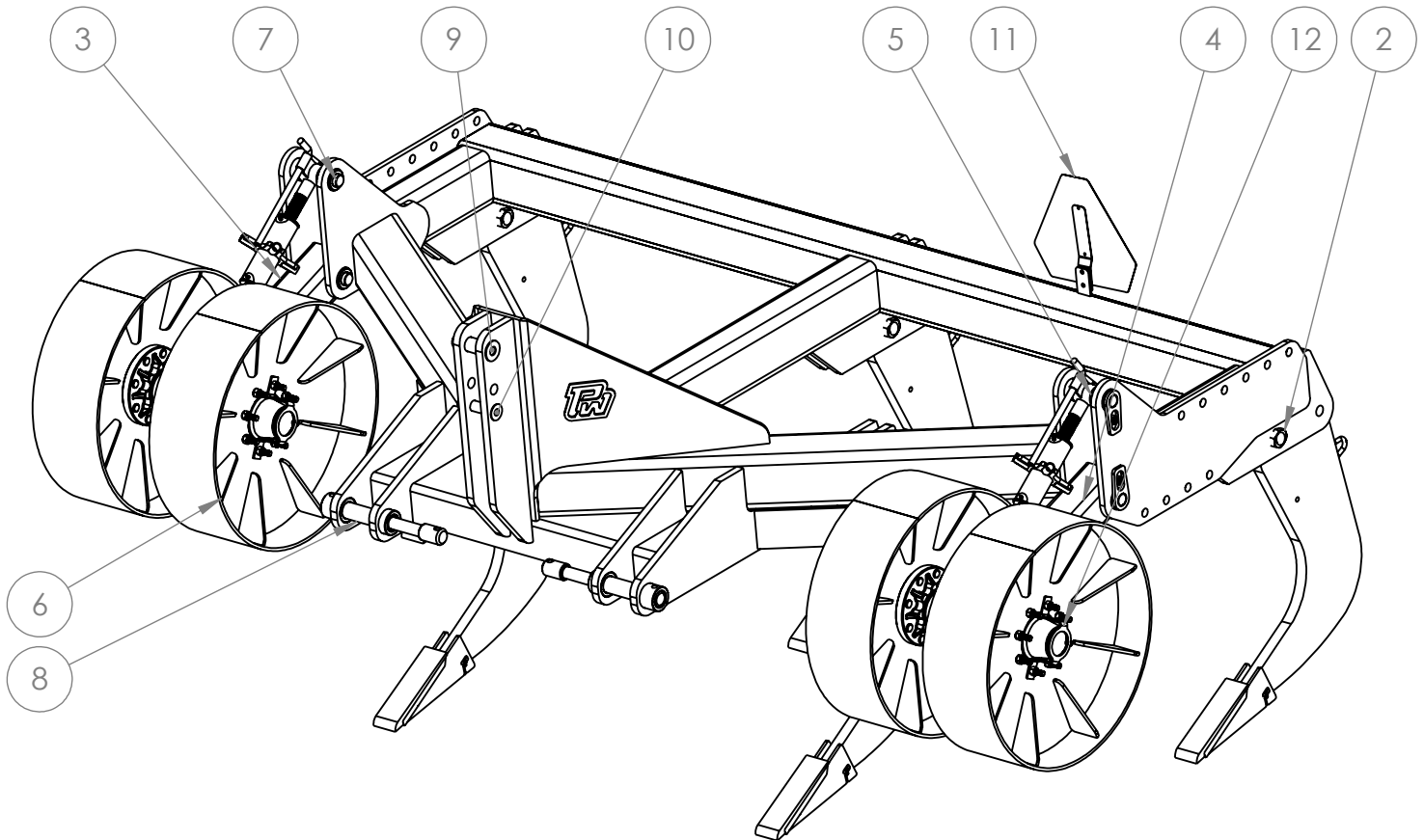

ITEM NO.	PART NUMBER	DESCRIPTION	5 ON 30/QTY.	20/QTY.	22/QTY.	24/QTY.	30/QTY.
1	PRS-CA001	36" SHANK ASSEMBLY* SEE PAGE 2	5	7	7	7	7
2	PW-LT121	SHEAR BOLT	5	7	7	7	7
3	3PR-CA001	TRAILING ARM FRONT RIGHT	1	1	1	1	1
4	3PR-CA001	TRAILING ARM FRONT LEFT	1	1	1	1	1
5	PFC-CA401	TURNBUCKLE ASSEMBLY	2	2	2	2	2
6	3PR-CA004	GAUGE WHEEL	4	4	4	4	4
7	PFF-A102	PIN 1 ASSEMBLY	4	4	4	4	4
8	PW-LT115	PULL PIN - CAT 3 & 4	2	2	2	2	2
9	PW-LA121	3PT UPPER PIN	1	1	1	1	1
10	PW-LA122	3PT PIN LOWER	1	1	1	1	1
11	PW-LA123	SMV	1	1	1	1	1
12	PW-LT128	DUSTCAP KEEPER	4	4	4	4	4

* THE SERIAL NUMBER OF THE EQUIPMENT IS REQUIRED

CALL YOUR LOCAL DEALER FOR PARTS

HEAVY DUTY 3 POINT RIPPER

PARTS BOOK

MODELS: H53630, H73620, H73622, H73624 & H73630



www.porterswelding.com

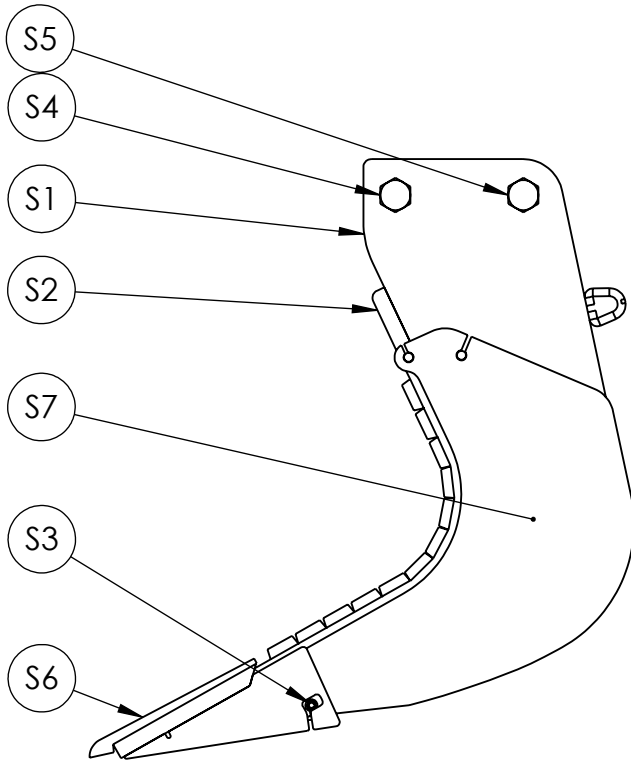

BOLT-ON

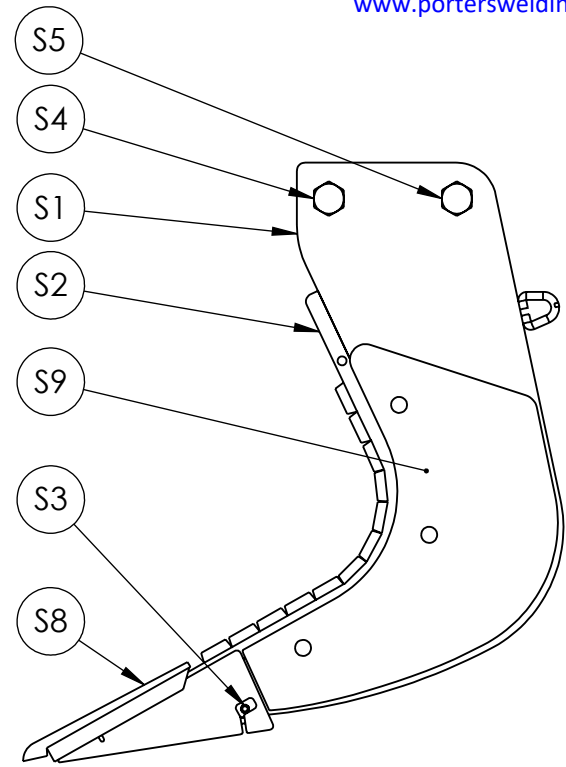

WELD-ON

ITEM NO.	PART NUMBER	DESCRIPTION	BOLT ON/QTY.	WELD ON/QTY.
S1	PRS-CT001	36" SHANK	1	1
S2	PRS-CT003	CHROME SHIN GUARD	1	1
S3	3R-PIN	3" ROLL PIN	1	1
S4	PW-LT121	SHEAR BOLT	1	1
S5	PB-125	PIVOT BOLT	1	1
S6	PRP-A101	2" RIPPER POINT	1	-
S7	PRS-CT002	BOLT-ON WEAR GUARD	2	-
S8	PRP-A102	1-1/2" RIPPER POINT	-	1
S9	36-WG	WELD-ON WEAR GUARD	-	2

MODEL	SHANK QTY
H53630	5
H73620	7
H73622	7
H73624	7
H73630	7

* THE SERIAL NUMBER OF THE EQUIPMENT IS REQUIRED

CALL YOUR LOCAL DEALER FOR PARTS