

STANDARD 3 POINT RIPPER

PARTS BOOK

MODELS: S53430, S73420, S73422, S73424 & S73430



www.porterswelding.com

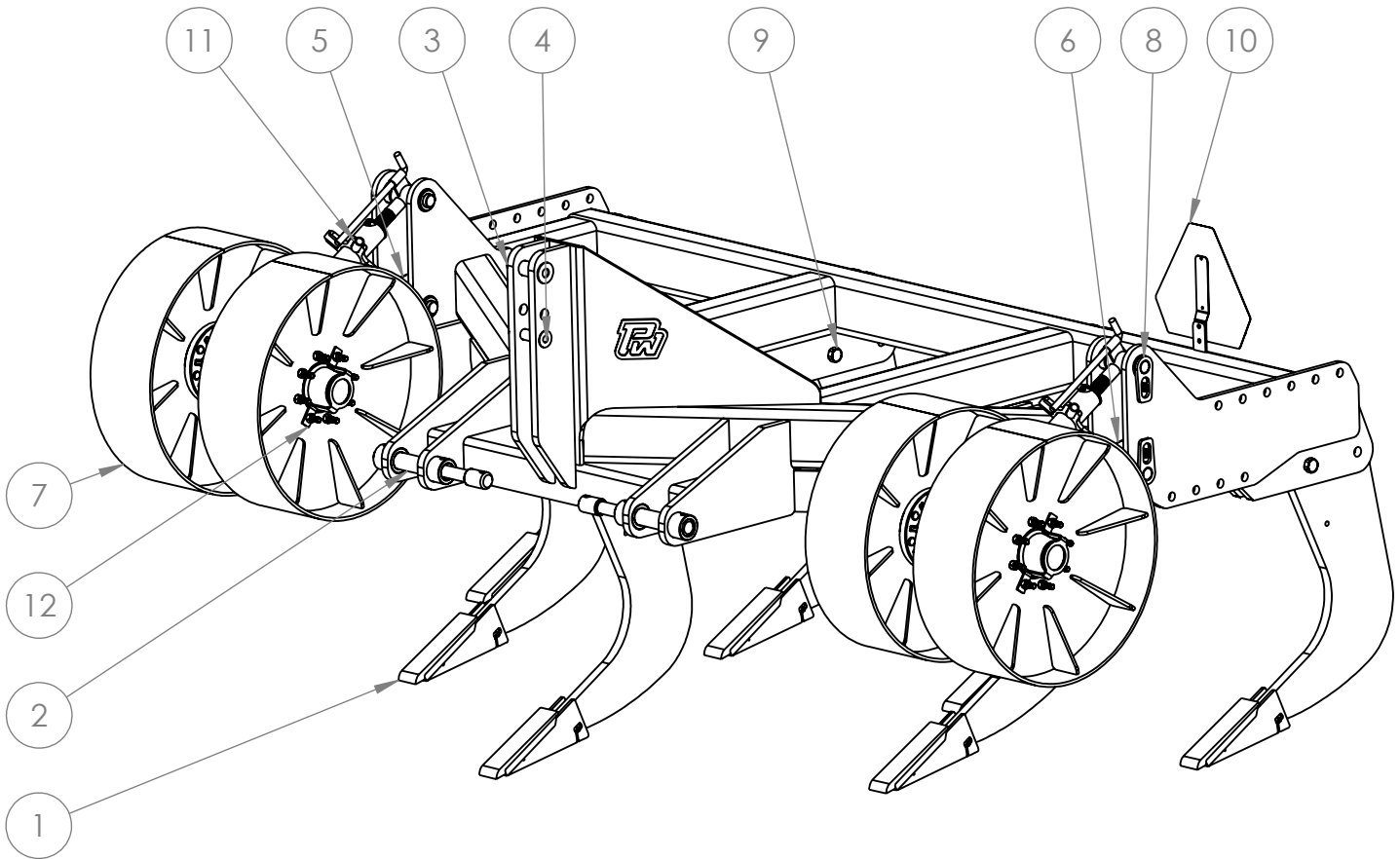

ITEM NO.	PART NUMBER	DESCRIPTION	5 on 30/QTY.	20/QTY.	22/QTY.	24/QTY.	30/QTY.
1	S3PR-CA205	34" SHANK* SEE PAGE 2	5	7	7	7	7
2	PW-LT115	PULL PIN - CAT 3 & 4	2	2	2	2	2
3	PW-LA121	3PT UPPER PIN	1	1	1	1	1
4	PW-LA122	3PT PIN LOWER	1	1	1	1	1
5	3PR-CA001	TRAILING ARM FRONT RIGHT	1	1	1	1	1
6	3PR-CA001	TRAILING ARM FRONT LEFT	1	1	1	1	1
7	3PR-CA004	GAUGE WHEEL	4	4	4	4	4
8	PFF-A102	PIN 1 ASSEMBLY	4	4	4	4	4
9	S3PR-CT011	SHEAR BOLT	5	7	7	7	7
10	PW-LA123	SMV	1	1	1	1	1
11	PFC-CA401	TURNBUCKLE ASSEMBLY	2	2	2	2	2
12	PW-LT128	DUSTCAP KEEPER	4	4	4	4	4

* THE SERIAL NUMBER OF THE EQUIPMENT IS REQUIRED

CALL YOUR LOCAL DEALER FOR PARTS

STANDARD 3 POINT RIPPER

PARTS BOOK

MODELS: S53430, S73420, S73422, S73424 & S73430



www.porterswelding.com

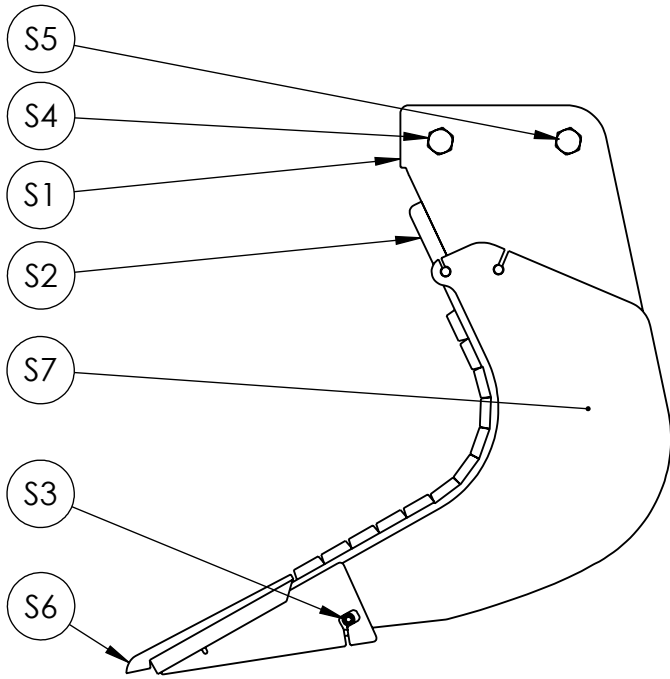

BOLT-ON

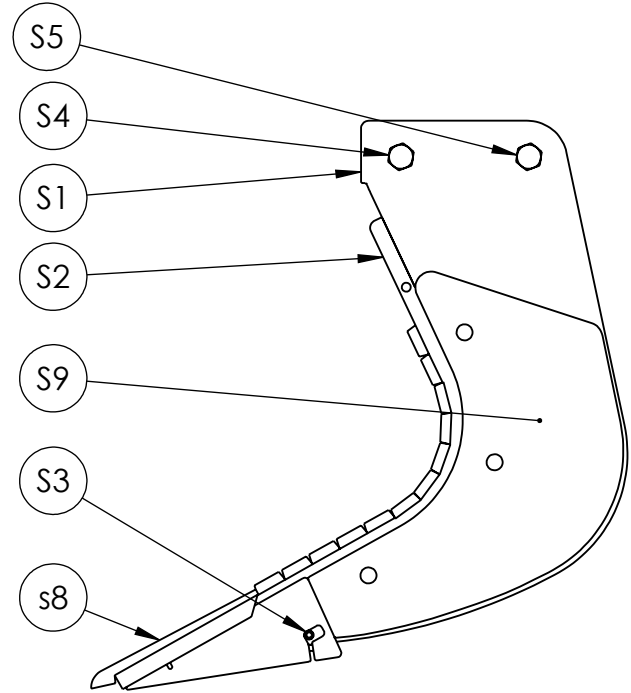

WELD-ON

ITEM NO.	PART NUMBER	DESCRIPTION	BOLT-ON/QTY.	WELD-ON/QTY.
S1	S3PR-CT001	34" SHANK	1	1
S2	S3PR-CT012	CHROME SHIN GUARD	1	1
S3	3R-PIN	3" ROLL PIN	1	1
S4	S3PR-CT011	SHEAR BOLT	2	2
S5	PB-112	PIVOT BOLT	1	1
S6	PRP-A105	1-7/8" RIPPER POINT	1	-
S7	PRS-CT002	BOLT-ON WEAR GUARD	2	-
S8	PRP-A103	1-1/4" RIPPER POINT	-	1
S9	36-WG	WELD-ON WEAR GUARD	-	2

MODEL	SHANK QTY
S53430	5
S73420	7
S73422	7
S73424	7
S73430	7

* THE SERIAL NUMBER OF THE EQUIPMENT IS REQUIRED

CALL YOUR LOCAL DEALER FOR PARTS

STANDARD 3 POINT RIPPER

PARTS BOOK

MODELS: S53430, S73420, S73422, S73424 & S73430

8 ON 8 HUB ASSEMBLY



www.porterswelding.com

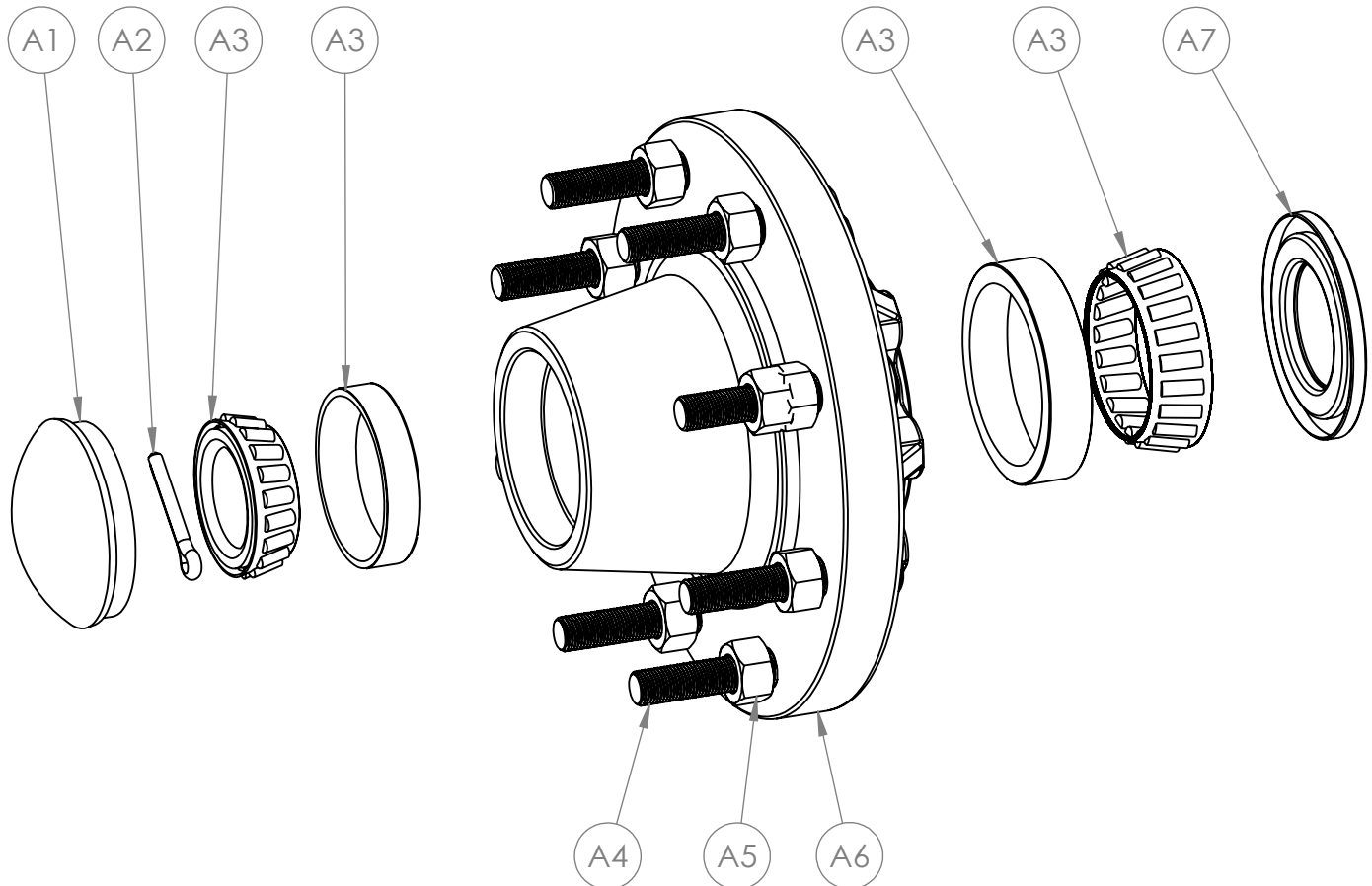

ITEM	PART NUMBER	DESCRIPTION	QTY
A1	PW-LWT015	DUST CAP	1
A2	PW-LWT009	COTTER PIN	1
A3	808-BER	BEARING KIT	1
A4	PW-LWT011	8 ON 8 STUD	8
A5	PW-LWT017	LUG NUT	8
A6	PW-LWT010	8 ON 8 HUB	1
A7	PW-LWT014	SEAL	1

* THE SERIAL NUMBER OF THE EQUIPMENT IS REQUIRED

CALL YOUR LOCAL DEALER FOR PARTS